

**TYPHOON**   
*PLUS*



**QUICK START  
GUIDE  
V2.0**

**YUNEEC**

## Overview

### Aircraft

Product Name: APV System  
Model Name: TYPHOON H PLUS

### Gimbal Camera

Product Name: 3-Axis Gimbal Camera  
Model Name: C23

### Controller

Product Name: Personal Ground Station  
Model Name: ST16S

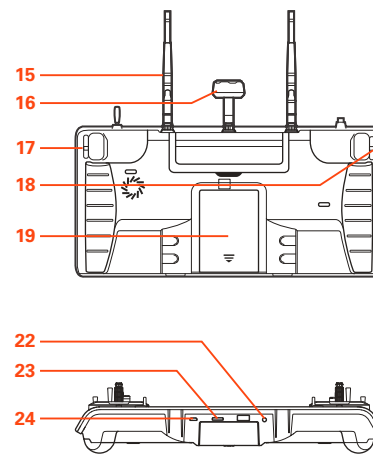
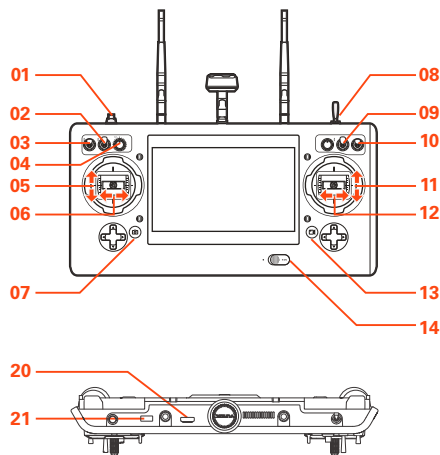
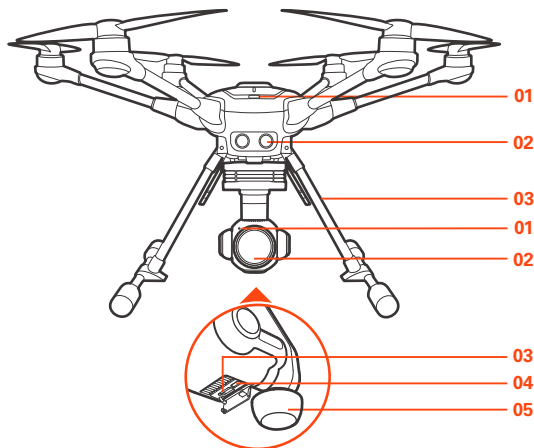

### TYPHOON H PLUS

- 01 Power Switch
- 02 Sonar
- 03 Retractable landing gear

### C23

- 01 Camera LED Status Indicator
- 02 Camera Lens
- 03 Micro SD Card Slot
- 04 USB Port
- 05 5GHz Antenna

### ST16S

- 01 Start/Stop Motor Button
- 02 Gimbal Pan Mode Switch  
(Follow Mode/ Follow Pan  
Controllable Mode/ Global Mode)
- 03 Gimbal Tilt Mode Switch  
(Angle Mode/Velocity Mode)
- 04 Gimbal Pan Control Knob
- 05 Throttle/Altitude Control (Mode 2)  
Elevator/pitch control (Mode 1)

- 06 Rudder/Yaw Control  
(Mode 2 and Mode 1)
- 07 Take Still Photo Button
- 08 Landing Gear Switch
- 09 Obstacle Avoidance Switch
- 10 Flight Mode Selection Switch
- 11 Elevator/ Pitch Control (Mode2)/  
Throttle/Altitude Control (Mode 1)
- 12 Aileron/Roll Control  
(Mode 2 and Mode 1)
- 13 Start/Stop Video Recording Button

- 14 Power Switch
- 15 2.4GHz Antenna
- 16 5GHz Antenna
- 17 Proportional Control Rate Slider
- 18 Gimbal Tilt Control Slider
- 19 Battery
- 20 HDMI
- 21 USB Port
- 22 Headset Port
- 23 Micro SD Slot
- 24 Micro USB Port

## Charge the Batteries

Power the desktop charger from a 100-240V AC outlet using the AC adapter/power supply, or from a 12V-17.4V DC accessory socket/cigarette lighter receptacle in an automobile using the included adapter. Plug the aircraft battery into the charger port as illustrated.

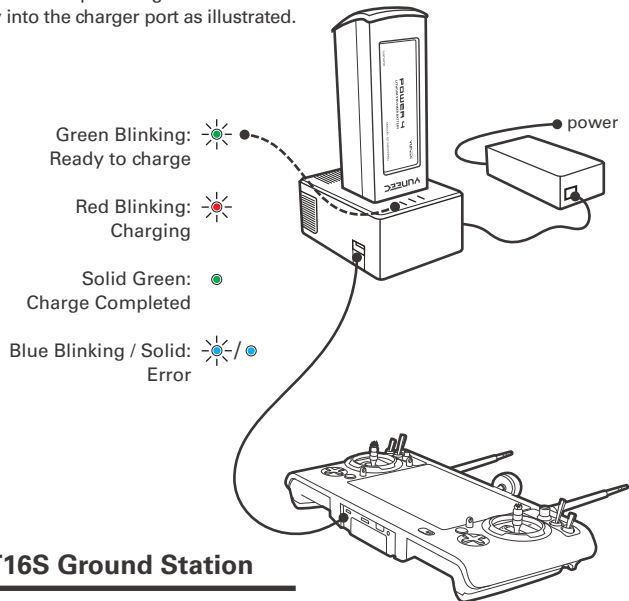

## ST16S Ground Station

Charge the ST16S battery by using supplied USB cable and inserting it into the Micro USB port on the charger. It will take approximately five hours to charge a fully discharge battery.

## Assembly

### Assembling the Arms

Unfold the motor arms and secure them until hearing a 'click'.

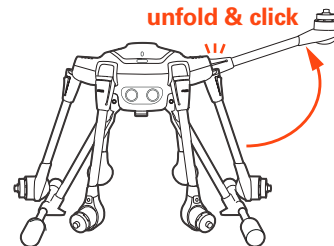

### Installing the Propellers

Mount propeller 'A' on motor 'A' and propeller 'B' on motor 'B'. Press and rotate propellers in the direction the [ A ] points to until the propellers lock. Cross-check to be sure propellers are properly locked in place.

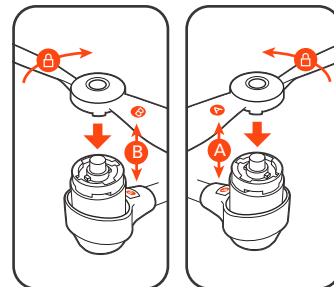

### Installing the Flight Batteries

Push the battery into the battery compartment until hearing a 'click'.

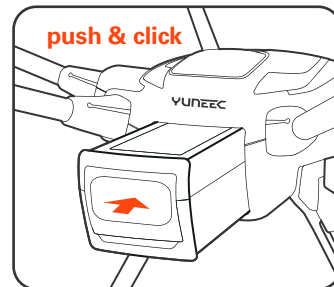

## Power ON / OFF

**NOTICE:** Please make sure all firmware is the latest version. Firmware and the user manual may be downloaded from web site: [www.yuneec.com](http://www.yuneec.com). The quick start guide does not replace the user manual.

Turn on the ST16S, and then press the power button on TYPHOON H Plus. Release the button when the aircraft emits a rising tone. Power on the ST16S before powering on the UAS.

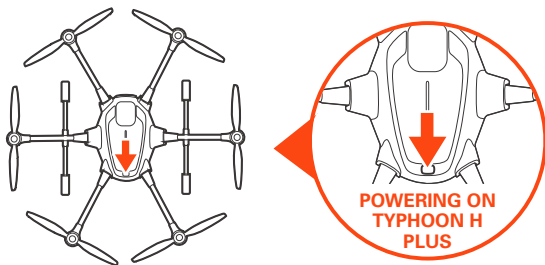
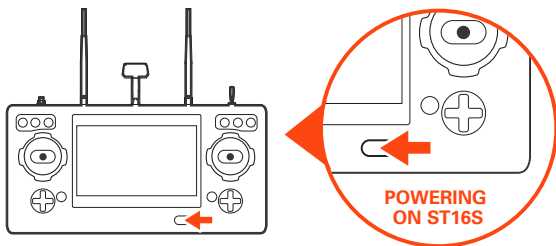

## Take Off

Press and hold the START/STOP button for about 3 seconds to start the motors in angle mode.

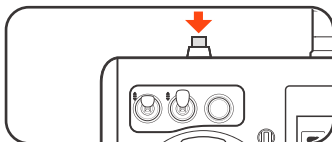

### OPTION 1:

Slowly raise the left-hand stick to take off.

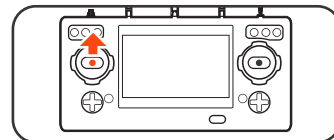

### OPTION 2:

Tap the icon [  ] and slide on the screen to take off.

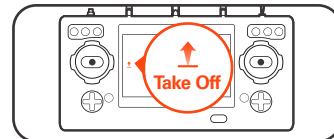

## Retract Landing Gears

Raise the landing gear control using the landing gear control switch on the ST16S.

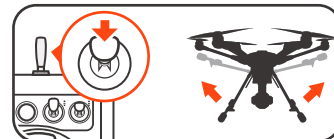

## Landing

**Step 1)** Lower the landing gear using the same control as used for retracting landing gear.

**NOTICE:** Lower the landing gear at least 12' above the landing area.

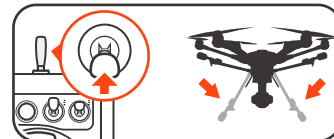

**Step 2)** Slowly lower the left-hand stick below the center position, TYPHOON H PLUS will descend slowly and land. After TYPHOON H PLUS lands, the motors will stop after 2 seconds without any operation.

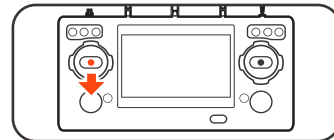

## Flight Control

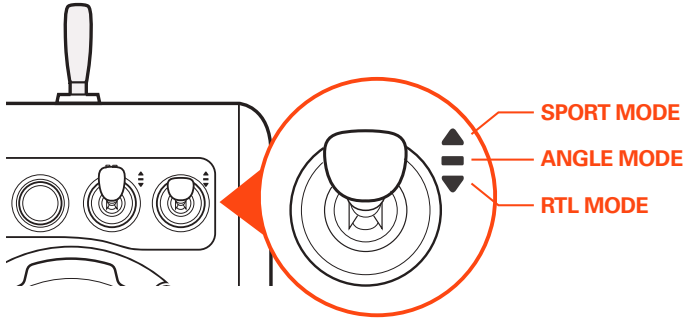

Never attempt to operate the TYPHOON H PLUS near tall buildings /obstructions that do not offer a clear view of the sky (a minimum clearance of 100°).



## ANGLE MODE

When in Angle Mode and GPS is available, the TYPHOON H PLUS will respond according to the ST16S remote controller.

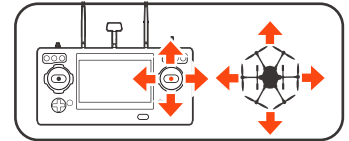
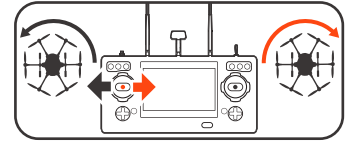

**Tips:** Fly low and slow initially. Slow (Lo Speed) position is ideal for precision flight. High-speed (Hi Speed) position is used when transiting broad areas.

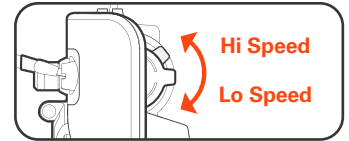

## SPORT MODE

The TYPHOON H PLUS has high reaction sensitivity in Sport Mode. The maximum flight speed of the aircraft is increased to 45mph (20m/s).

## RTL MODE

When in RTL Mode, TYPHOON H PLUS will return to the home point and automatically lower the retractable gear to land.

## TASK MODE

### Follow Me

The Follow Me function allows the TYPHOON H PLUS to follow the pilot, adjusting its location to the location of the ST16S Ground Station.

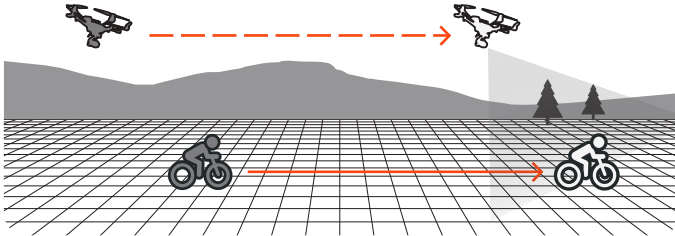

### CCC (Curve Cable Cam)

Curve Cable Cam allows you to create an invisible route for TYPHOON H PLUS to fly along. Once the pilot sets the points, the TYPHOON H PLUS will fly the set coordinates while remembering the heading.

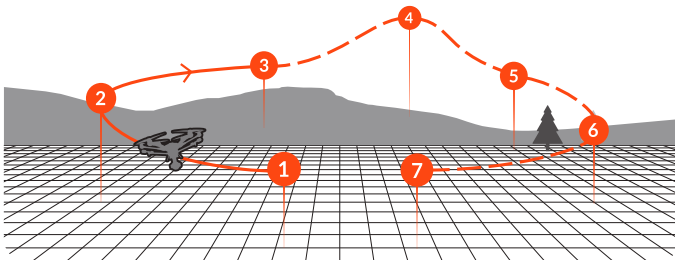

### POI (Point of Interest)

Point of Interest allows the pilot to select a subject they would like to orbit and have TYPHOON H PLUS orbit that subject autonomously.

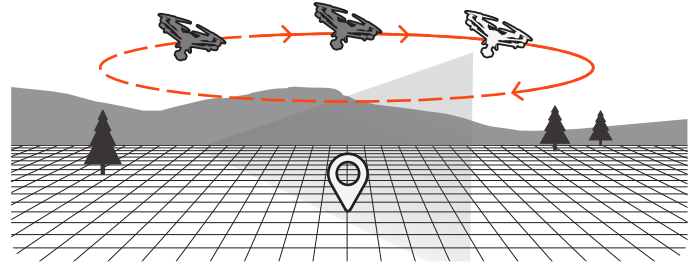

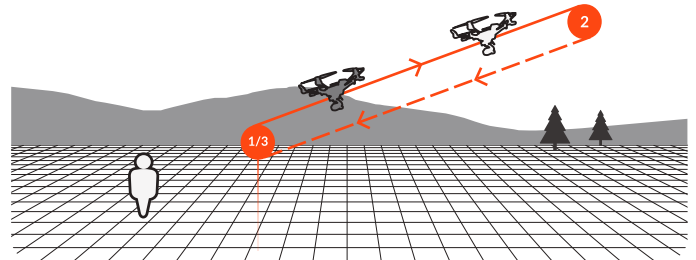

### JOUR

Journey function enables TYPHOON H PLUS to capture the perfect aerial selfie easier and faster. Depending on the pilot's desired setting, TYPHOON H PLUS will go up, out and return.



## Camera Control

### Taking Photos and Recording Video

Taking photos and recording video can be switched by tapping [  ] and [  ] icons.

### To Take A Still Photo

Press the icon [  ], or press the button located near the bottom left corner of the ST16S.

### To START/STOP Recording Video

Press the icon [  ], or press the button located near the bottom on the right corner of the ST16S.

**NOTICE:** Please make sure the SD card has been inserted into the camera before taking photos and recording video.

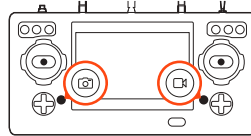

## LED Status Indications

All the LEDs mentioned are numbered as shown.

The color of the icon indicates the color of the LED.

 indicates the LED flashing.

 indicates the LED solid on.

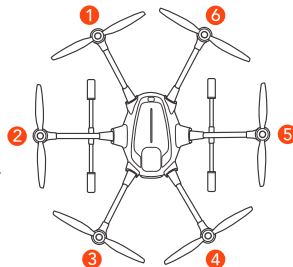

## STATUS

Initiate Compass Calibration

 2-5-3-6-4-1-5-2-6-3-1-4

Accelerometer/  
Gyro Calibration Completed



During Initialization



Rotor Abnormal Alarming



The Aircraft is in Binding Mode



Low Voltage Battery Warning



Binding Failed



Calibration Failed



The Aircraft is in Sport Mode



The Aircraft is in Angle Mode  
(without GPS lock)



The Aircraft is in Angle Mode  
(with GPS lock)



The Aircraft is in RTL Mode



The Aircraft is in Task Mode



The Aircraft is in IPS Mode



First / Second Level Low Voltage  
Battery Warning



Compass Alarming



The Aircraft is in No-Fly Zone



OBS. Function Activated



**YUNEEC**

Any information might be changed due to the software update. For the latest documents, please check the official website: [www.yuneeec.com](http://www.yuneeec.com)